

A02. CLASSIC MONOLITHIC & OEM COMPATIBLE PANEL SYSTEM



OEM COMPATIBLE

A02. A CLASSIC PERFORMER. OEM COMPATIBLE*.

A02 is a classic monolithic panel system designed to be stand-alone, interchangeable with, or work in tandem with Herman Miller® Action Office Series 2. A02's core product engineering is based upon this well-known, proven, high-end system, but enhanced to provide the end-user an even stronger panel construction with additional features.

The A02 system offers fabric and glass panels in varying heights with a 6" base raceway to meet demanding electrical and data needs. With virtually unlimited worksurfaces, components, accessories and finish options, A02 is the ideal combination of performance and value. These features coupled with its compatibility with Herman Miller® Action Office®, make A02 a sensible value-based option to expand an existing office space for less.



*OEM is standard used to explain the product can be integrated with the original Herman Miller Action Office 2 system. Certain electrical components may not be compatible and some finish colors may vary from different OEM color specifications. Refer to your AIS representative with questions on compatibility.

Herman Miller® and Action Office® are registered trademarks of Herman Miller, Inc., Zeeland, Michigan.



5 DAY QUICKSHIP

5 DAY QUICKSHIP. AWARD-WINNING MANUFACTURING.

AIS offers a 5-day quickship program which is unrivaled by any other systems manufacturer. If you need your workstations manufactured in 5 days or less, reach out to your AIS Sales Representative for assistance. We will meet your demands. Because of our award-winning lean manufacturing AIS is able to provide competitive lead-times with an extensive palette of finish options at no extra charge. This is why AIS has continued to grow, increasing market share year-after-year.

AIS's excellence in lean manufacturing has earned high praise, including the Shingo Prize for excellence in lean manufacturing, and recognition by Industry Week magazine as one of the top 25 manufacturing plants in North America.





LIMITLESS DESIGN

THE POSSIBILITIES ARE ENDLESS.

A02 provides you the flexibility to design your space to meet your needs. Panels are offered in 3 heights, 6 widths and quarter-glass, half-glass and full-glass options.

From cluster working environments to private offices, you can design A02 to work for you. Utilize low-panel heights to boost a teaming environment, or integrate high panels to create an increasingly private configuration. Couple your chosen layout with storage options and an Element Executive chair to create a complete office space.





BUILT FOR LIFE

PERFORMANCE AND PRACTICALITY.

A02 is built for life, backed by the AIS lifetime warranty, one of the most comprehensive in the industry. With the AIS Non-Obsolescence Policy, AIS is committed to providing our customers with products of equal or similar appearance, compatibility, and operational characteristics, protecting your investment.

AIS stands behind its products and engineers them to meet stringent stability, safety and environmental standards. A02 systems meet and exceed ANSI/BIFMA standards, and are GREENGUARD Certified. Additionally, A02 is comprised of 59.6% recycled content by weight, offering you a sensible, earth-friendly solution that may contribute to LEED credits.





PANEL SPECIFICATIONS.

- Panels are constructed of a rigid honeycomb core, trimmed with a steel frame.
- Each panel is 2" thick, with a 3 3/8" raceway.
- Metal trim with PVC raceway.
- Panels can be specified with ¼, ½, and full glass.
- Panels are available in tackable, acoustical, tackable/acoustical and fabric over hard surface.

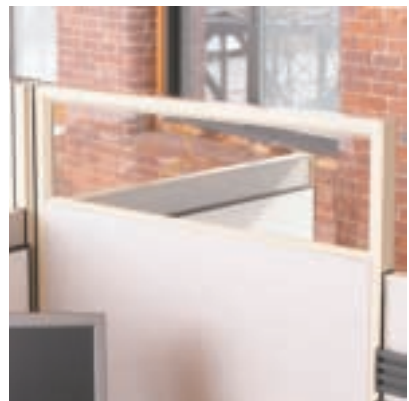
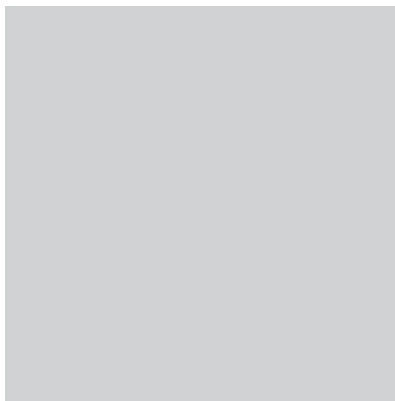
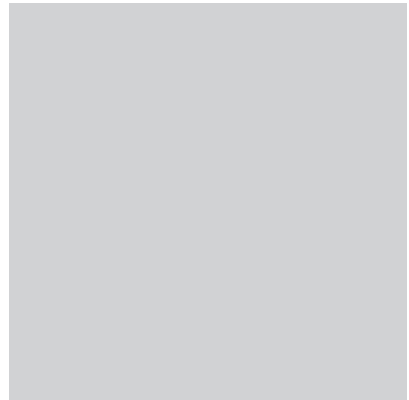



1



2



3



4



5



6



7

ACCESSORIES.

- 1 AIS offers flipper doors painted, fabric-covered, and laminated to suit your style. Flipper door units are the perfect storage solution, also available in radius cover.
- 2 Easily integrate tool rails with the A02 system. Choose from a variety of paper management tools, shelves, pencil trays, folder sorters and more.
- 3 Mid-height shelves can be integrated to truly customize any employee's workspace.
- 4 Keyboard trays can be mounted to any worksurface for advanced ergonomics.
- 5 Whiteboards in 12 different sizes can be integrated into any A02 workspace.
- 6 AIS standard loop pull pedestals are available in box/box/file and file/file configurations.
- 7 Maximize storage capacity with side-by-side pedestals in a variety of configurations.

DATA & ELECTRICAL.

The enhanced power and data capacity of the A02 panel raceway meets the challenge of today's technically demanding work environments.

A02 offers lay-in power and data capacity for easy installation with high capacity for up to 100 pairs of Category 5 or Category 6 cables in a non-powered raceway.

AIS A02 system is compatible with older OEM* electrical systems. Consult your AIS representative to identify the best solution for your particular application.



*OEM is standard used to explain the product can be integrated with the original Herman Miller Action Office 2 system. Certain electrical components may not be compatible and some finish colors may vary from different OEM color specifications. Refer to your AIS representative with questions on compatibility.



THE DURABILITY COMMITMENT.

A02's durable, all-metal panel end caps withstand heavy-duty wear and tear.

A02 is a proven performer. With one of the most simple, yet sturdy panel connection designs in the market, A02 bridges performance and practicality.



STORAGE AND FILE SOLUTIONS

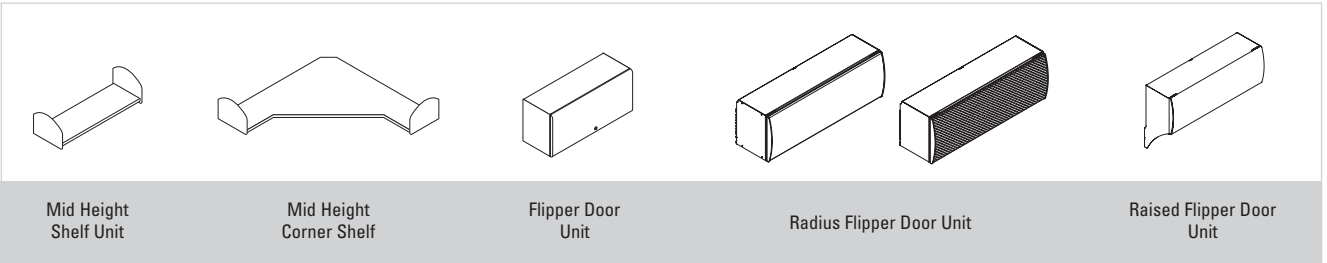

SHELVES / FLIPPER DOORS

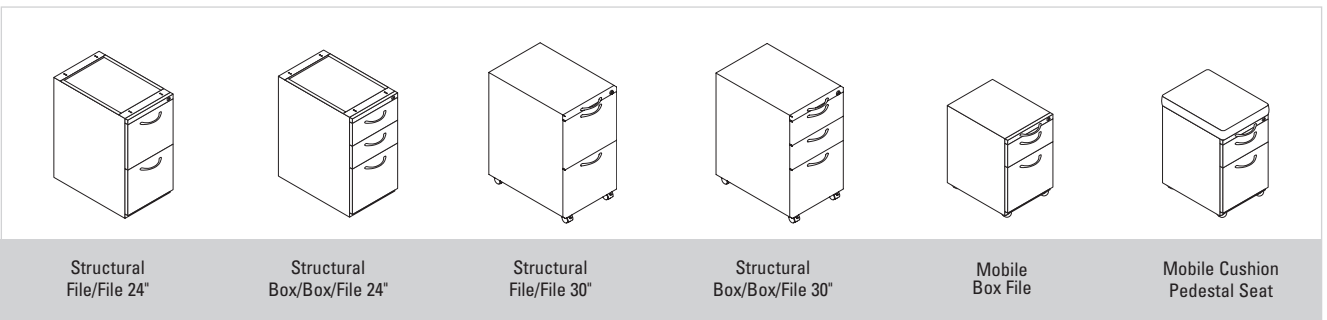

PEDESTALS

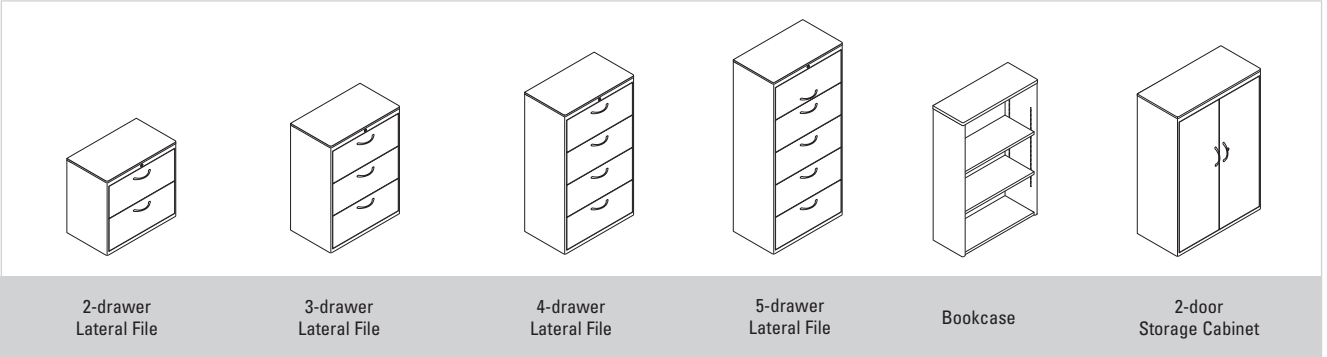

BOOKCASES, 2-DOOR CABINETS LATERAL FILES

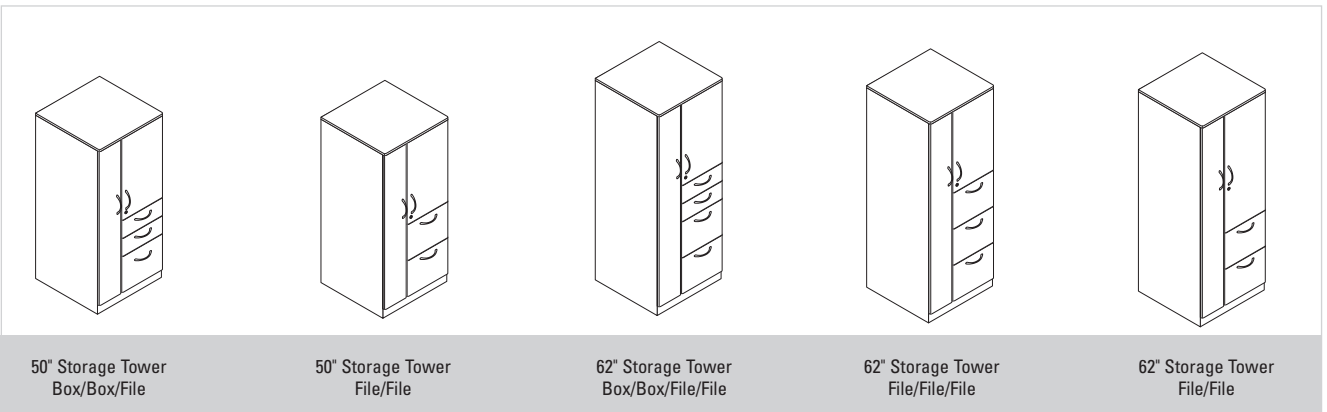

WARDROBE STORAGE TOWERS



THE STANDARD. FOR ANY ENVIRONMENT.

A02 offers you an exceptional value for your work environment even as AIS sets a high standard for preserving and improving the world's environment. For several years, in fact, we have led our industry in developing and implementing Green and Lean manufacturing practices. A testament of our commitment is being the first and only systems furniture manufacturer to be awarded the prestigious Shingo Award for excellence in lean manufacturing. By working with like-minded suppliers, we have pioneered efforts in eliminating waste and reducing potentially harmful toxins and VOCs. AIS also adheres to the stringent GREENGUARD standards and engineers and manufactures its products with this standard in mind. We will continue to devote ourselves to manufacturing lean products that are sensitive to the environment and indoor air quality.



4 Bonazzoli Avenue Hudson, MA 01749
800.434.7400 978.562.7500 Fx 978.562.0811
www.ais-inc.com

For additional information on AIS:
Dealer Showrooms
Representative Directory
Project Case Studies
Online Catalog & Product Showcase
Visit: www.ais-inc.com

